

Appendix F: General Notes, Standard Drawings and Standard Details

Details are currently available in pdf and AutoCAD format and may be downloaded from [Rogue Valley Sewer Services website](#).

Construction Notes and Material Specifications for Stormwater Facilities

These notes must be included on the plans for all BMPs.

List of Standard Drawings

BMP 4.4.1.a Poned Retention: Rain Garden

BMP 4.4.1.b Poned Retention: Rain Garden Planting Schematic

BMP 4.4.1.c Poned Retention: Stormwater Planter with Area Drain

BMP 4.4.1.d Poned Retention: Stormwater Planter Planting Schematic

BMP 4.4.2.a Pervious Surface: Pervious Concrete Pavement

BMP 4.4.2.b Pervious Surface: Pervious Asphalt Pavement

BMP 4.4.2.c Pervious Surface: Permeable Pavers

BMP 4.4.2.d Pervious Surface: Vehicular Permeable Paver Edges

BMP 4.4.3.a Underground Retention: Soakage Trench in Landscape Area

BMP 4.4.3.b Underground Retention: Soakage Trench under Impervious Pavement Surface

BMP 4.5.1. Soil Filtration

BMP 4.5.2.a Water Quality Swale

BMP 4.5.2.b Water Quality Swale: Planting Schematic

BMP 4.5.3 Vegetated Filter Strip with Amended Planting Soil

Standard Details

1.01 Roadway Curb Opening

1.02 Check Dam

1.03 Flow Spreader

1.04 Forebay

1.05 Tree Protection

1.06 Tree Protection – Temporary Access Road

1.07 Tree Planting

1.08 Tree Planting on Slope

CONSTRUCTION NOTES AND MATERIAL SPECIFICATIONS FOR STORMWATER FACILITIES

THESE NOTES MUST ACCOMPANY ALL STANDARD DRAWINGS.

GENERAL STORMWATER CONSTRUCTION NOTES

1. All Stormwater facilities must be constructed per the Design Manual, or as approved by the local jurisdiction.
2. Call the reviewing agency 48 hours in advance of constructing this facility so construction observation may be performed to identify variations in the field that may affect design and verify proper construction.
3. For infiltration facilities, exposed facility subgrade shall be fenced to prohibit impacts from construction (including materials and equipment storage). If unprotected subgrade has been exposed to rainfall, scarify the surface to a depth of 4 inches to restore filtration capacity.
4. Placement of amended native or imported soil mix shall occur as follows:
 - Conduct excavation, fine grading and placement work only when the facility and soil to be placed is dry. Do not place if soil is saturated.
 - Place soil in 8 inch maximum lifts.
 - Lightly compact each lift, (e.g. a water filled landscape roller) to achieve 85% compaction. Do not compact with heavy machinery or vibratory compaction.
5. All ground within the facility must be stabilized with one of the options below, also see Material Specifications for Stormwater Facilities.
 - **Hydroseeding** – Hydroseeding with tackifier.
 - **Matting** – Matting shall be used to hold the soil in place until vegetation becomes established. If hand seeding, place seed and then install erosion control matting. If planting, install erosion control matting and then install plants through the matting. Matting is not required on slopes 4H:1V or shallower, or on slopes that have been hydroseeded. Matting must be biodegradable.
 - **Mulch** – Mulch is not allowed below the water quality ponding depth or within the flow path of an inlet or outfall. Mulch shall be spread over bare soil or in a ring around plants. Ensure that mulch does not touch plant stems.
6. If soil is placed during the wet season the facility must be stabilized within one week of soil installation.

CONSTRUCTION NOTES FOR VEGETATED STORMWATER BMPS

7. Build and vegetate as early as possible to establish plantings prior to directing stormwater runoff to the BMP.
8. Contact approving jurisdiction 48 hours in advance of planting so that the jurisdiction can review soil installation and plant placement prior to plant installation.

CONSTRUCTION NOTES FOR PERVIOUS SURFACE STORMWATER BMPS

9. Contact the approving agency 48 hours prior to placing geotextile fabric. The approving agency may call the engineer of record in advance of constructing this facility so construction observation may be performed to identify variations in the field that may affect design and verify proper construction.

MATERIAL SPECIFICATIONS FOR STORMWATER FACILITIES

1. Growing media must be Imported Planting Soil or Amended Native Soil at the depths shown on the Standard Drawings and meet the following specifications:

- a) **Imported Water Quality Mixture** – Is based on the ODOT “Water Quality Mixture” 01012, and shall be comprised of soil meeting the gradation in the table below and compost meeting ODOT Standard Specification Section 03020.

Soil Gradation Requirements	
Sieve Size	Percent Passing (by Weight)
No. 4	100
No 10	95 - 100
No. 40	40 - 60
No. 100	10 - 25
No. 200	5 - 10

Mix the soil and compost so the Imported **Water Quality Mixture**:

- Is comprised of between 20%-25% compost and between 75%-80% soil.
- Has a pH between 5.5 and 8.0.
- Does not have clumps greater than 3 inches in any direction.

- b) **Amended Native Soil** – Add compost so that the top 18 inches is roughly 30% compost meeting ODOT Standard Specification Section 03020.

- i) The approving jurisdiction may request evidence that the Amended Native Soil or Imported Water Quality Mixture meets specification prior to placement. If requested, test data for the soil mix shall be provided by an accredited laboratory with current certification. The date of the analyses must be no more than 90 days prior to submittal. The report must include the following:
- Name and address of the laboratory
 - Phone, contact and email address of the laboratory
 - Test data, including date and name of the test procedure
 - Source of the topsoil

2. Mulch shall be a 2 inch thick layer of dye, pesticide, and weed free shredded wood chips or coarse compost.
3. Stormwater facility geotextiles shall be ODOT Drainage Geotextiles Type 1, non-woven, per Standard Specification Section 03020. Geotextile under the road base in 4.5.3 shall be Subgrade Geotextile meeting ODOT Standard Specification Section 02320.
4. Impermeable liners may be a 30 mil (minimum) high density polyethylene (HDPE), 30 mil (minimum) ethylene propylene diene monomer (EPDM), polyvinyl chloride (PVC), or bentonite clay mat per manufacturer guidance.
 - a. Stormwater facilities with liners that are planted with shrubs must have 24 inches of imported soil.
5. Unless otherwise approved, rock for Pervious Surface BMP's and Stormwater Facilities shall be crushed rock per ODOT Standard Specification Sections 00430.11 (Granular Drain Backfill Material) or 02690.20 (Course Aggregate) and meet the following gradations:

	Percent Passing (by weight)		
	Designated Sizes		
	Granular Drain Backfill	Granular Drain Backfill	Course Aggregate
Sieve Size	1 1/2" - 3/4"	3/4" - 1/2"	3/8" – No. 8
2"	100	-	-
1 1/2"	95 - 100	-	-
1"	-	100	-
3/4"	0 - 15	90 - 100	-
1/2"	0 - 2	0 - 15	100
3/8"	-	-	85 - 100
1/4"	-	0 - 3	-
No. 4	-	-	10 - 30
No. 8	-	-	0 - 10
No. 16	-	-	0 - 5

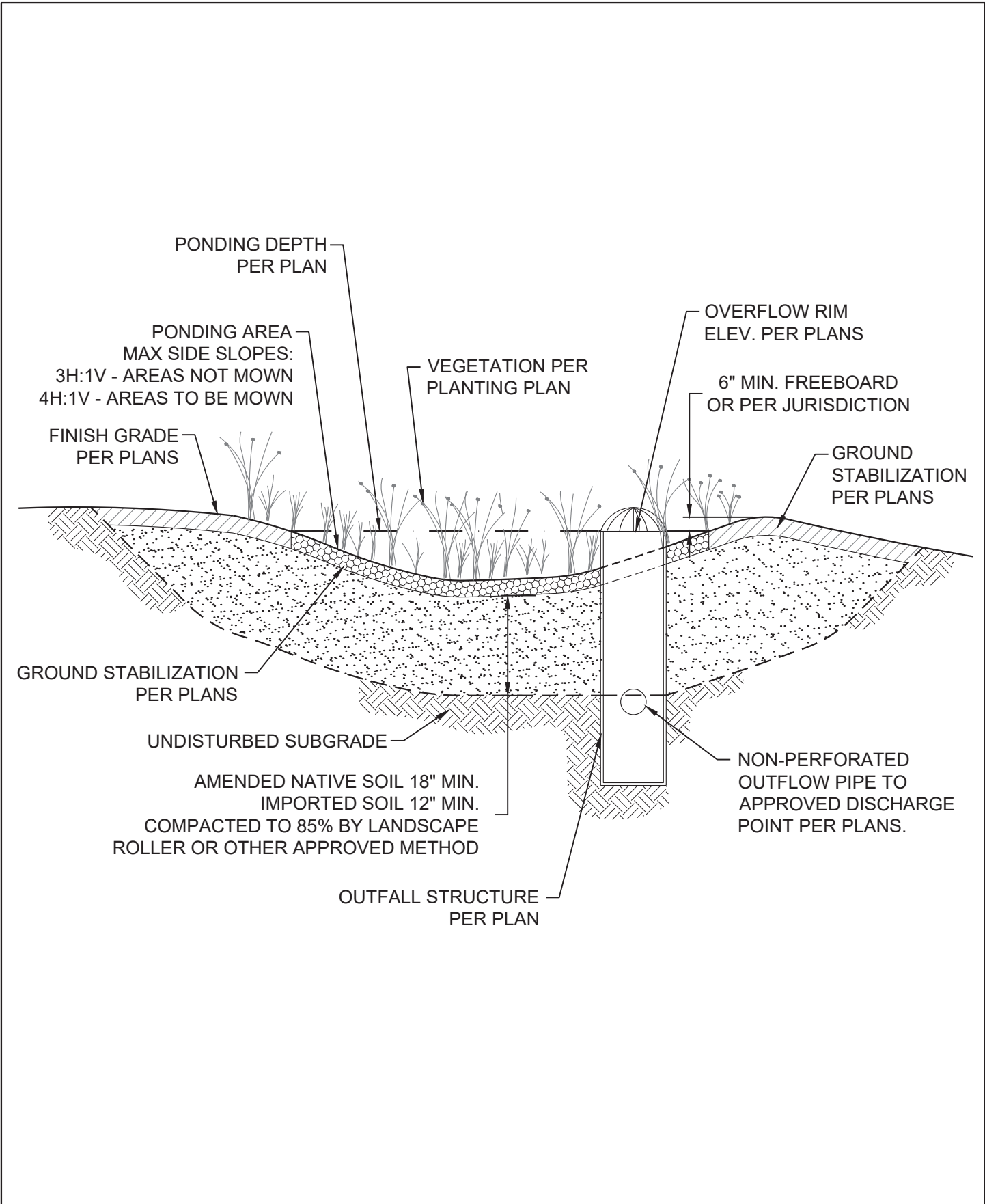

<p>Rogue Valley Stormwater Design Manual</p>	<p>Pondered Retention: Rain Garden</p>	<p>BMP 4.4.1.a 1 of 1 Scale: NTS</p>
--	--	--

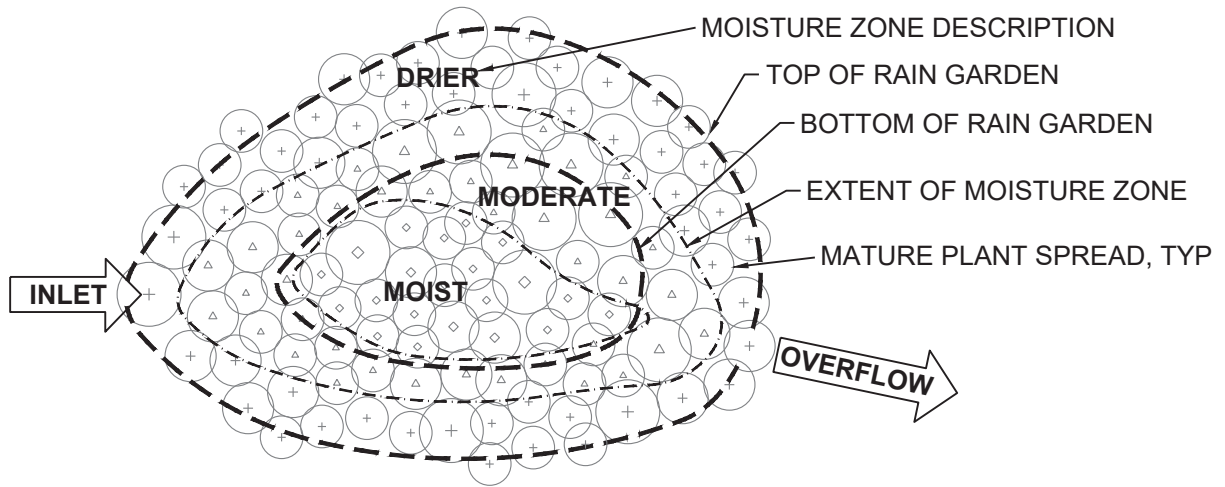

PROFILE VIEW

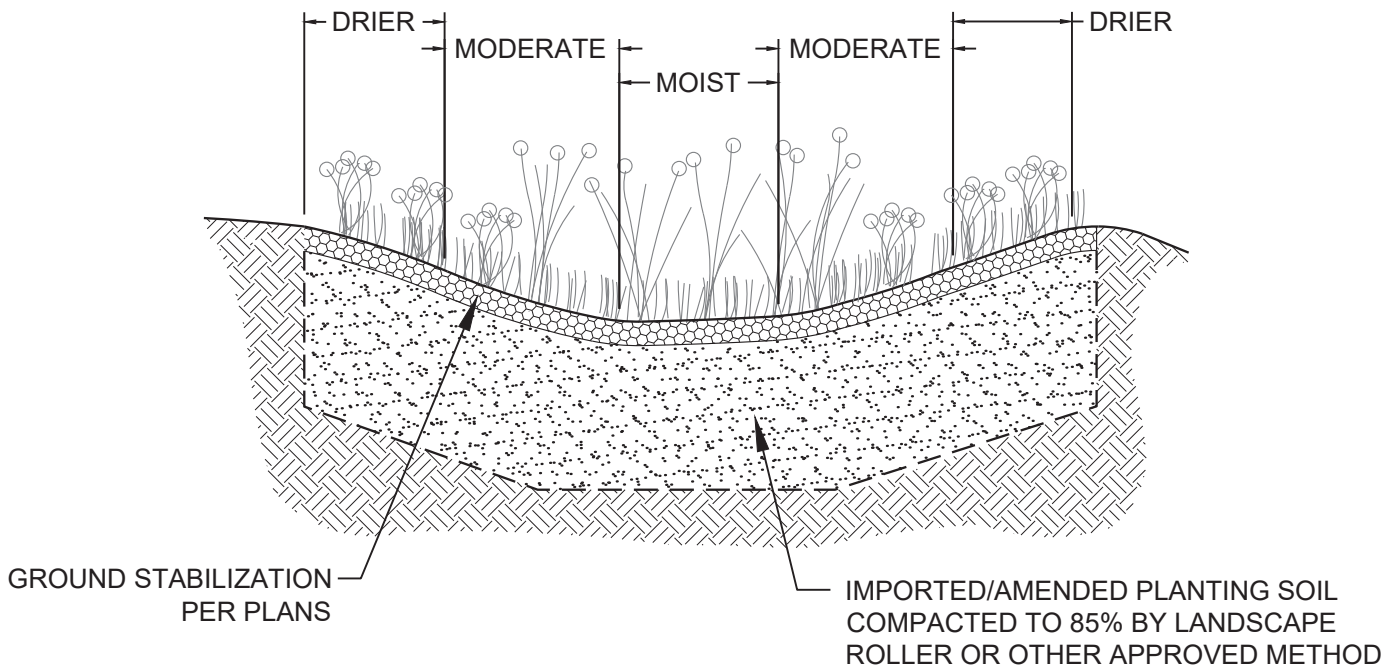

LEGEND:

— — CONTOUR LINE

- · - MOISTURE ZONE

PLANT SPECIES APPROPRIATE FOR MOISTURE ZONE:

⊕ DRIER

⊕ MODERATE

⊕ MOIST

NOTES:

1. THIS DETAIL IS PROVIDED AS A SCHEMATIC EXAMPLE OF THE RANDOM PLANT PLACEMENT AND 95% COVERAGE AFTER ESTABLISHMENT PERIOD DESIRED TO REDUCE EROSION AND WEEDS.
2. INSTALL PLANTS PER PLANS, ACCORDING TO LANDSCAPE DESIGN PLANT TABLE, WHICH SHOULD INCLUDE PLANT SPECIES, SPACING, AND QUANTITIES IN EACH MOISTURE ZONE.
3. MOISTURE ZONES VARY FROM THOSE SHOWN DEPENDING ON GRADING PLAN, LOCATION OF INLET (S) AND OUTLET(S) AND FACILITY SHAPE.

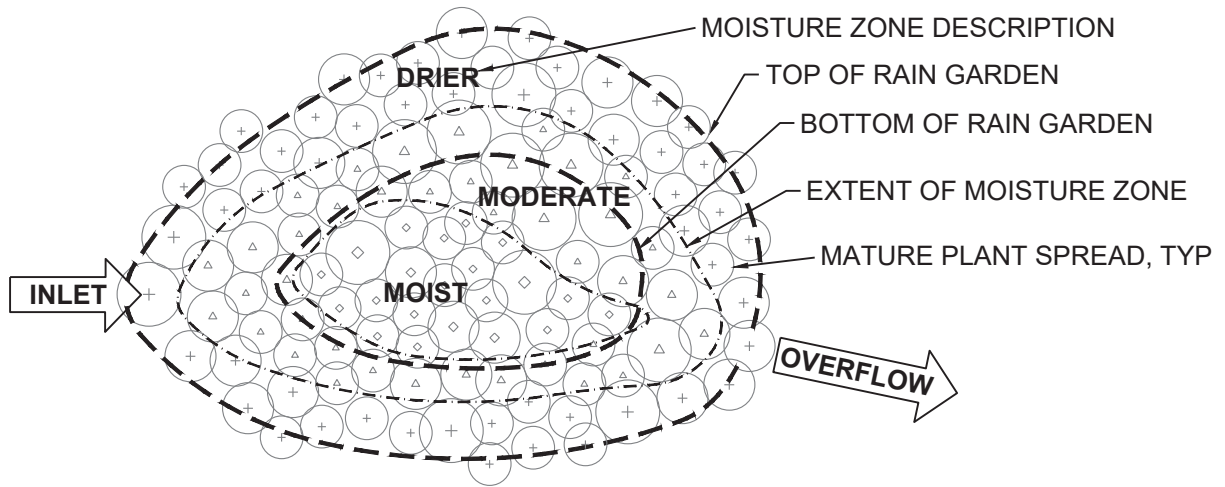

PROFILE VIEW

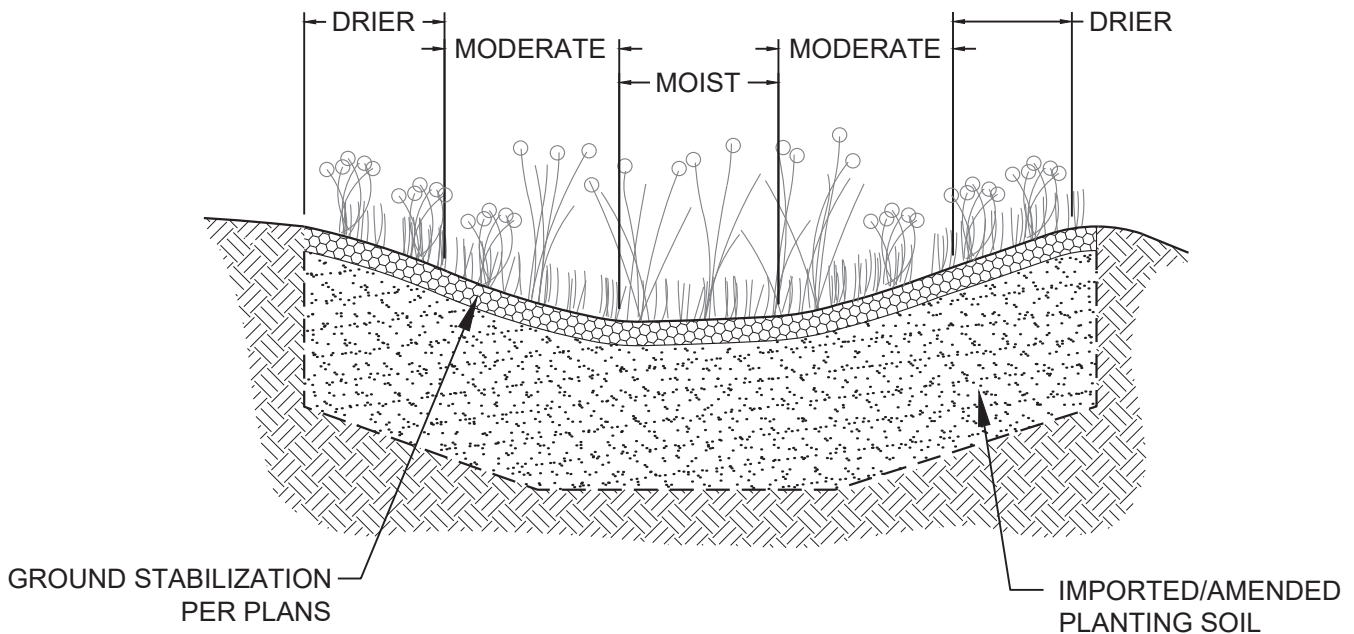

LEGEND:

— — CONTOUR LINE

- · - MOISTURE ZONE

PLANT SPECIES APPROPRIATE FOR MOISTURE ZONE:

⊕ DRIER

⊕ MODERATE

⊕ MOIST

NOTES:

1. THIS DETAIL IS PROVIDED AS A SCHEMATIC EXAMPLE OF THE RANDOM PLANT PLACEMENT AND 95% COVERAGE AFTER ESTABLISHMENT PERIOD DESIRED TO REDUCE EROSION AND WEEDS.
2. INSTALL PLANTS PER PLANS, ACCORDING TO LANDSCAPE DESIGN PLANT TABLE, WHICH SHOULD INCLUDE PLANT SPECIES, SPACING, AND QUANTITIES IN EACH MOISTURE ZONE.
3. MOISTURE ZONES VARY FROM THOSE SHOWN DEPENDING ON GRADING PLAN, LOCATION OF INLET (S) AND OUTLET(S) AND FACILITY SHAPE.

<p>Rogue Valley Stormwater Design Manual</p>	<p>Ponded Retention: Rain Garden Planting Schematic</p>	<p>BMP 4.4.1.b 1 of 1 Scale: NTS</p>
--	---	--

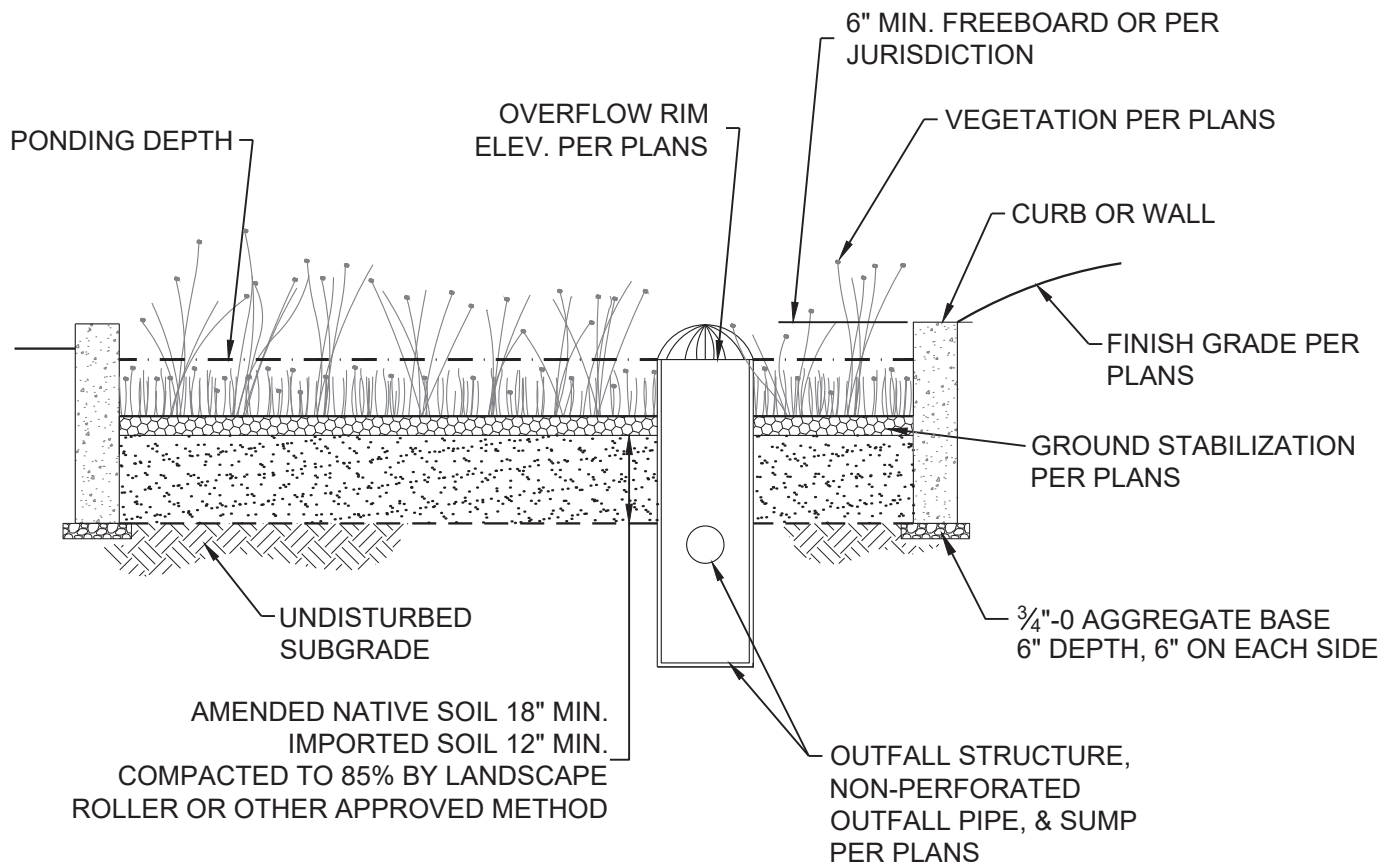

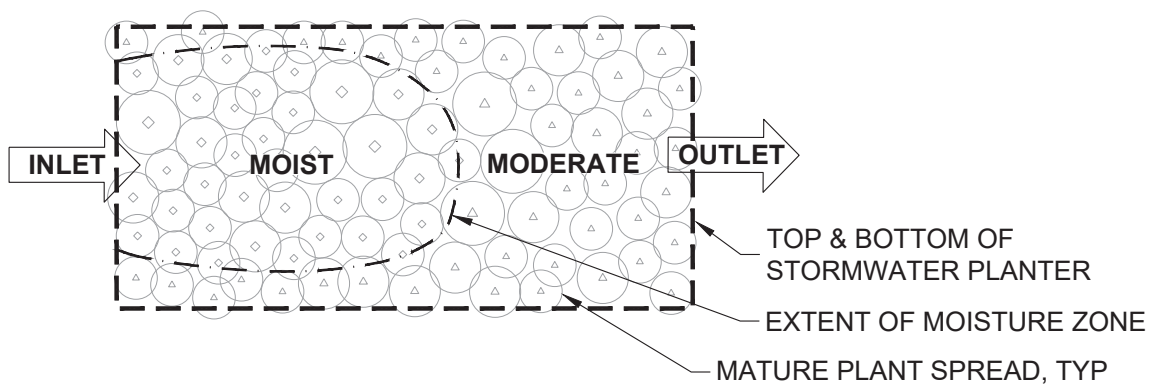

LEGEND:

— — CONTOUR LINE

- · - MOISTURE ZONE

PLANT SPECIES APPROPRIATE FOR MOISTURE ZONE:

△ MODERATE

◇ MOIST

NOTES:

1. THIS DETAIL IS PROVIDED AS A SCHEMATIC EXAMPLE OF THE RANDOM PLANT PLACEMENT AND 95% COVERAGE AFTER ESTABLISHMENT PERIOD DESIRED TO REDUCE EROSION AND WEEDS.
2. INSTALL PLANTS PER PLANS, ACCORDING TO LANDSCAPE DESIGN PLANT TABLE , WHICH SHOULD INCLUDE PLANT SPECIES, SPACING, AND QUANTITIES IN EACH MOISTURE ZONE.
3. MOISTURE ZONES VARY FROM THOSE SHOWN DEPENDING ON GRADING PLAN, LOCATION OF INLET (S) AND OUTLET(S) AND FACILITY SHAPE.

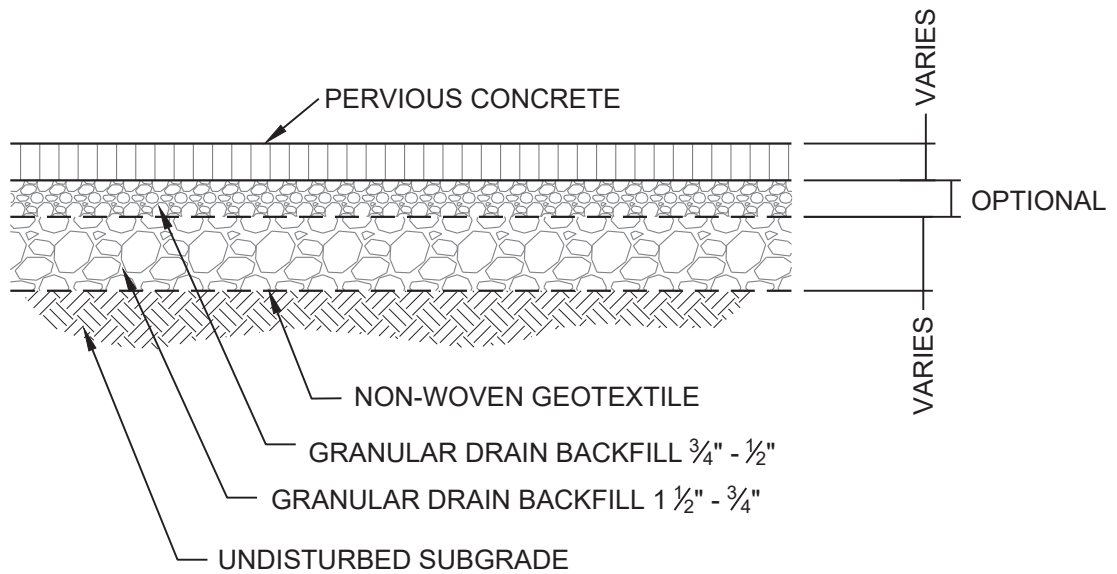

NOTES

- DESIGN AND INSTALL PERVIOUS CONCRETE IN ACCORDANCE WITH AMERICAN CONCRETE INSTITUTE SPECIFICATION 522 AND THE NATIONAL READY MIXED CONCRETE ASSOCIATIONS (NRMCA) RECOMMENDATIONS.

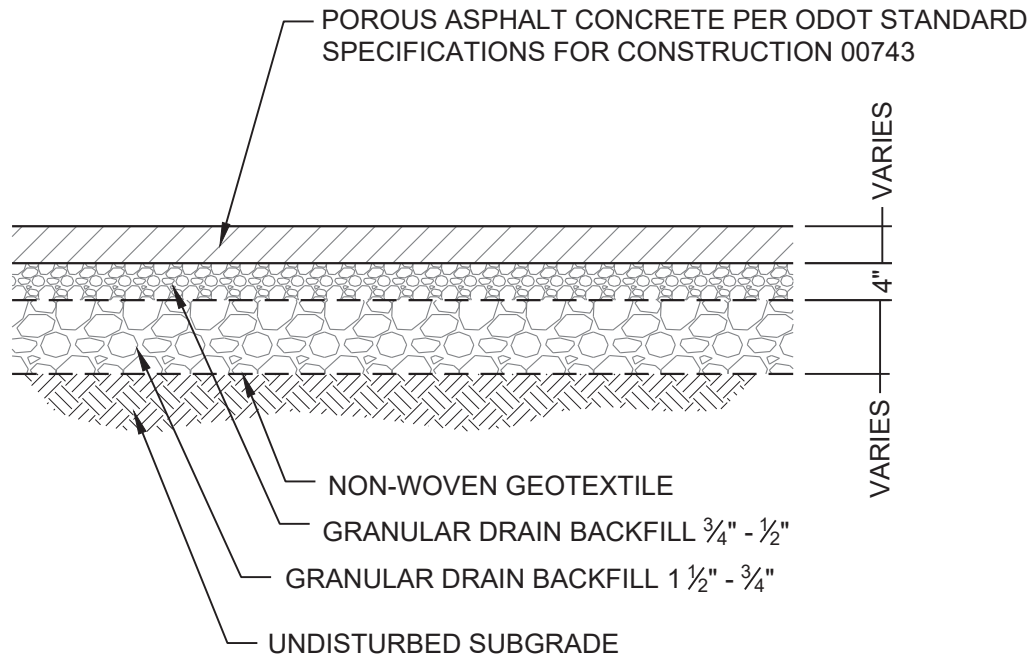

NOTES

1. FOLLOW ODOT SPECIFICATION 00743 POROUS ASPHALT CONCRETE.
2. MUST USE ELASTOMERIC BINDER PG7022ER, OR APPROVED EQUAL.
3. MUST PROVIDE THE JOB MIX FORMULA TO THE APPROVING AGENCY PRIOR TO CONSTRUCTION.

<p>Rogue Valley Stormwater Design Manual</p>	<p>Pervious Surface: Pervious Asphalt Pavement</p>	<p>Dwg BMP 4.4.2.b 1 of 1</p>
--	--	---------------------------------------

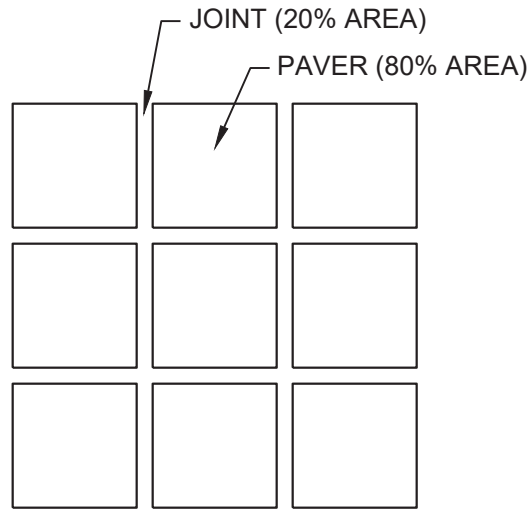
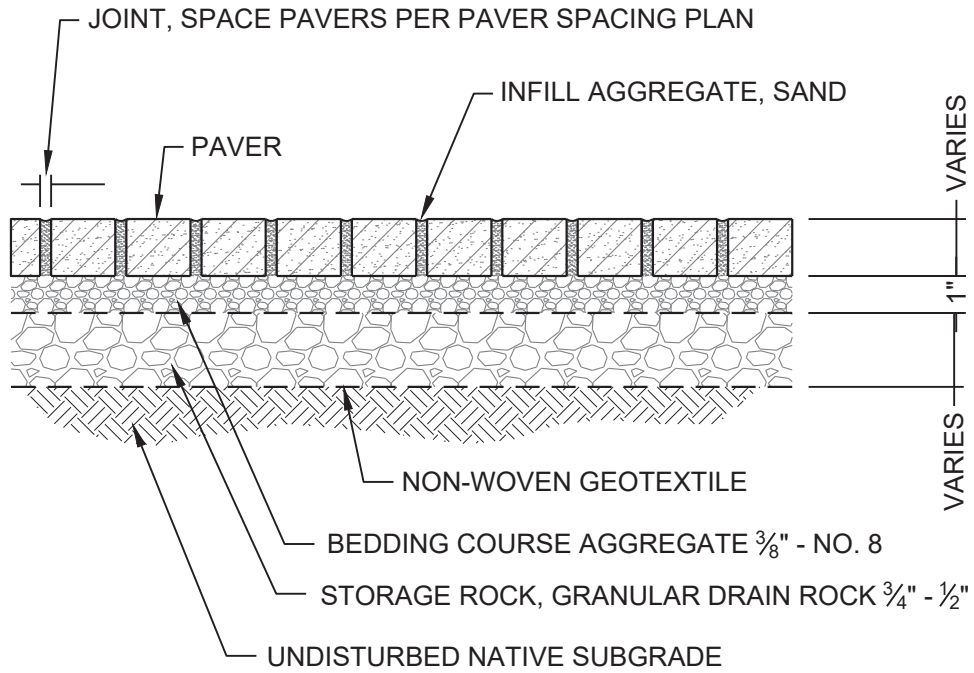

Paver Spacing Plan

NOTES

1. DESIGN & INSTALL CONCRETE PAVERS IN ACCORDANCE WITH THE INTERLOCKING CONCRETE PAVEMENT INSTITUTE (ICPI) SPECIFICATIONS & THE MANUFACTURER'S RECOMMENDATIONS.
2. IF USING SALVAGED AND POURED CONCRETE PAVERS, CONFIRM THAT THE PAVER MATERIAL AND CONDITION IS SUITABLE FOR ITS INTENDED USE.

<p>Rogue Valley Stormwater Design Manual</p>	<p>Pervious Surface: Permeable Pavers</p>	<p>Dwg BMP 4.4.2.c 1 of 1</p>
--	---	---------------------------------------

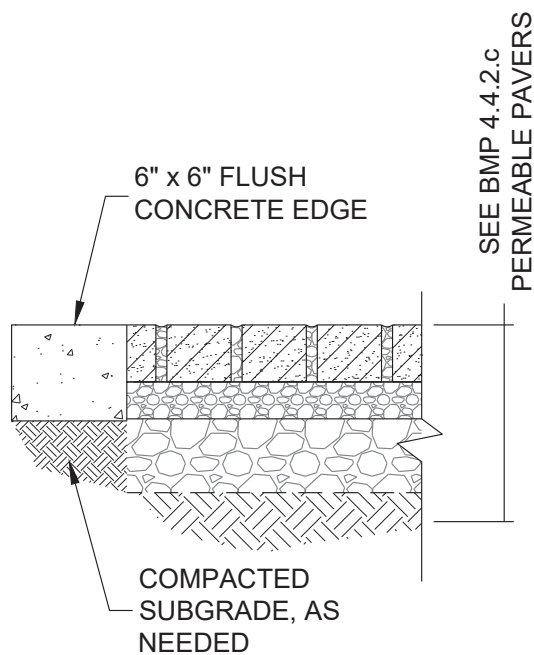

FLUSH CURB

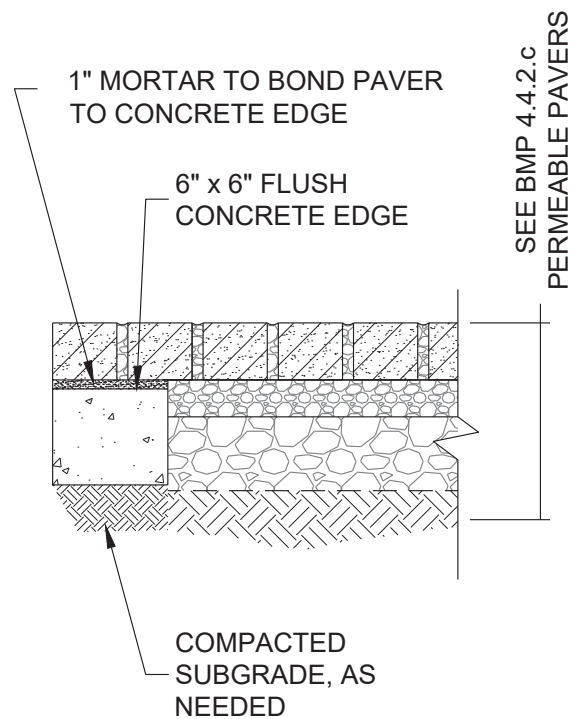

HIDDEN CURB

NOTES

1. DURING INSTALLATION OF CURB, PROTECT PERMEABLE PAVER AREA FROM COMPACTION.

<p>Rogue Valley Stormwater Design Manual</p>	<p>Pervious Surface: Vehicular Permeable Paver Edges</p>	<p>Dwg BMP 4.4.2.d 1 of 1</p>
--	--	---------------------------------------

Soakage Trench in Landscape Area

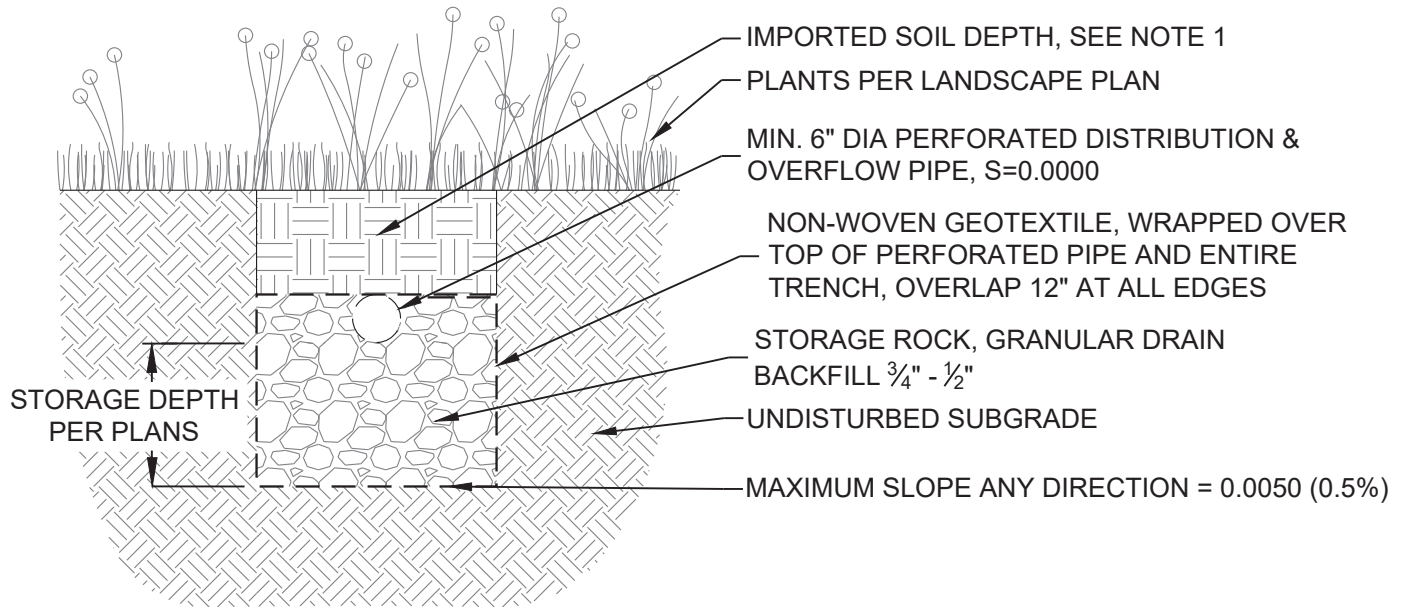

NOTES

1. DEPTH TO PIPE MUST BE 12" MINIMUM FOR ADEQUATE SOIL DEPTH PER PLANT CHOICES:
 12" FOR GRASSES/FORBS
 24" FOR SHRUBS
 36" FOR MOST TREES
 COMPACTED TO 85% BY LANDSCAPE ROLLER OR OTHER APPROVED METHOD

Soakage Trench at Surface

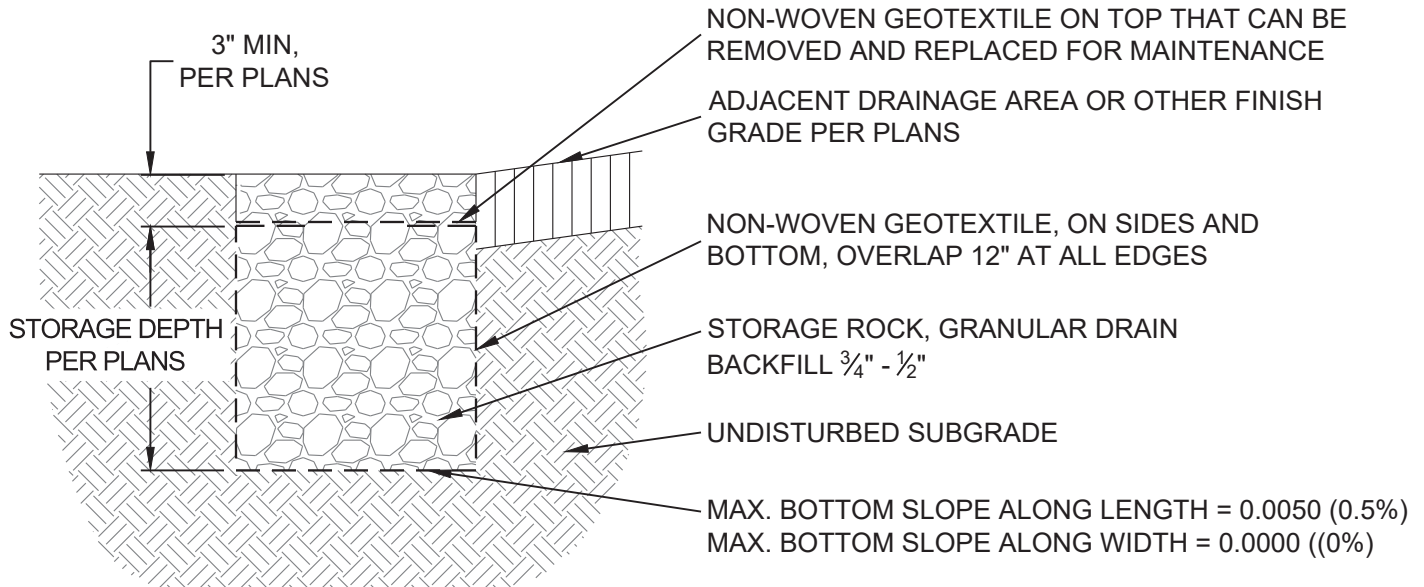

UIC AUTHORIZATION (NOT ALWAYS REQUIRED):

IF WATER IS DIRECTLY DISCHARGED TO THE SUBSURFACE, THE FACILITY MAY BE CONSIDERED A UIC AND MIGHT REQUIRE DEQ AUTHORIZATION. CONTACT DEQ TO FIND OUT ABOUT CURRENT UIC REGULATIONS AND WHETHER AUTHORIZATION WILL BE REQUIRED. DEQ'S UIC WEBPAGE: [HTTP://WWW.OREGON.GOV/DEQ/WQ/WQPERMITS/PAGES/UIC.ASPX](http://www.oregon.gov/deq/wq/wqpermits/pages/uic.aspx).

<p>Rogue Valley Stormwater Design Manual</p>	<p>Underground Retention: Soakage Trench in Landscape Area</p>	<p>BMP 4.4.3.a 1 of 1 Scale: NTS</p>
--	--	--

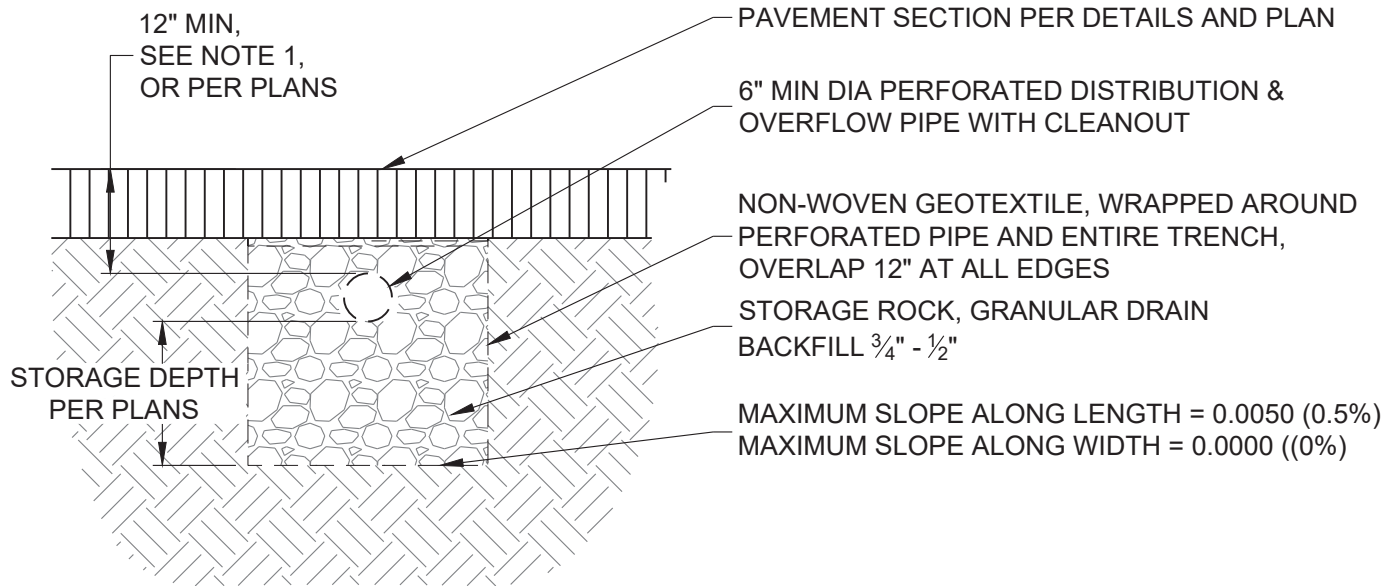

NOTES

1. PROVIDE DEPTH TO PIPE NEEDED FOR ADEQUATE COVER BASED ON VEHICULAR LOADING, WHICH VARIES WITH PIPE MANUFACTURER.

UIC AUTHORIZATION (NOT ALWAYS REQUIRED):

IF WATER IS DIRECTLY DISCHARGED TO THE SUBSURFACE, THE FACILITY MAY BE CONSIDERED A UIC AND MIGHT REQUIRE DEQ AUTHORIZATION. CONTACT DEQ TO FIND OUT ABOUT CURRENT UIC REGULATIONS AND WHETHER AUTHORIZATION WILL BE REQUIRED. DEQ'S UIC WEBPAGE: [HTTP://WWW.OREGON.GOV/DEQ/WQ/WQPERMITS/PAGES/UIC.ASPX](http://www.oregon.gov/deq/wq/wqpermits/pages/uic.aspx).

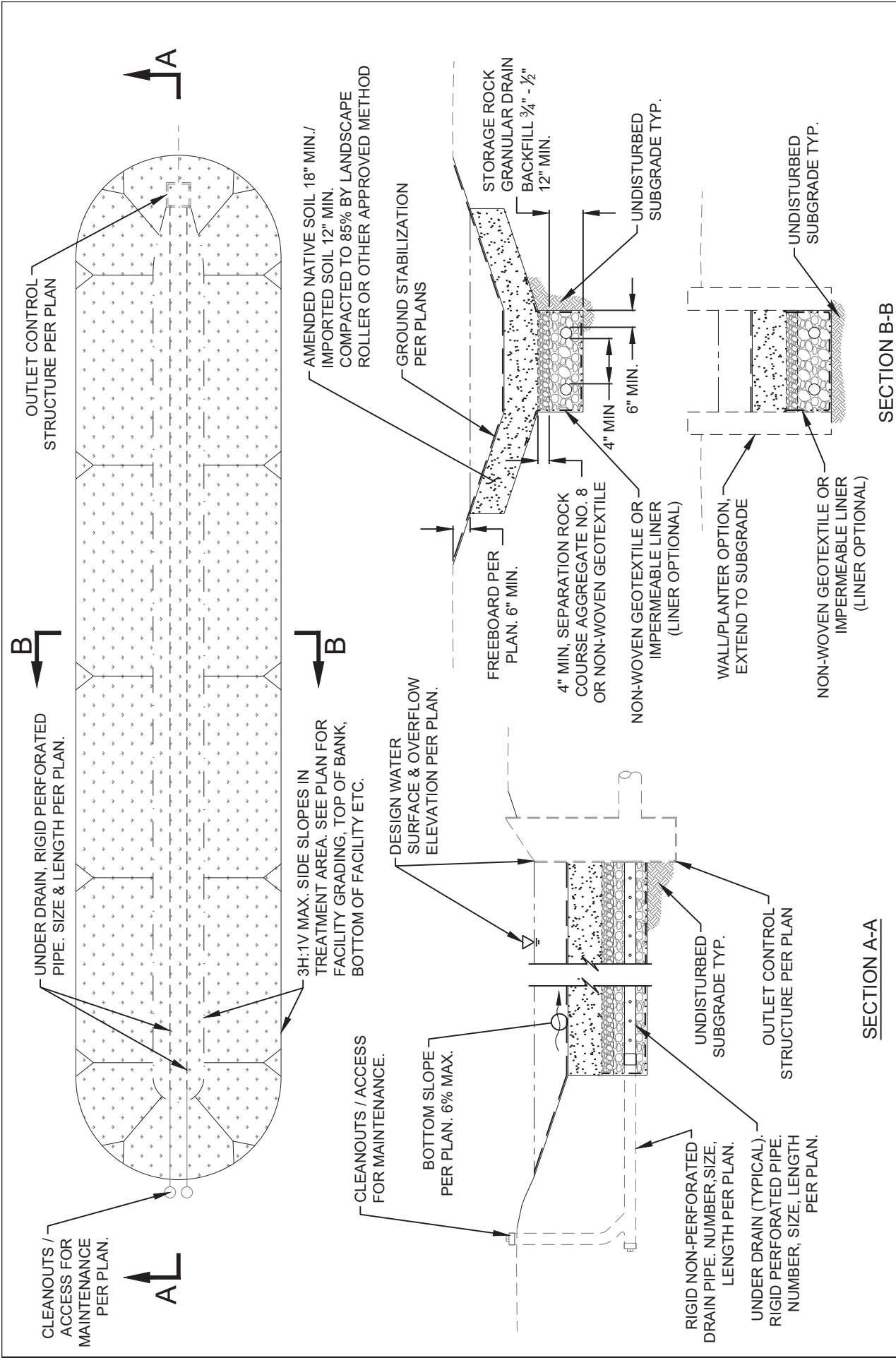

<p>Rogue Valley Stormwater Design Manual</p>	<p>Soil Filtration</p>
<p>BMP 4.5.1 1 of 1 Scale: NTS</p>	<p>SECTION B-B</p>

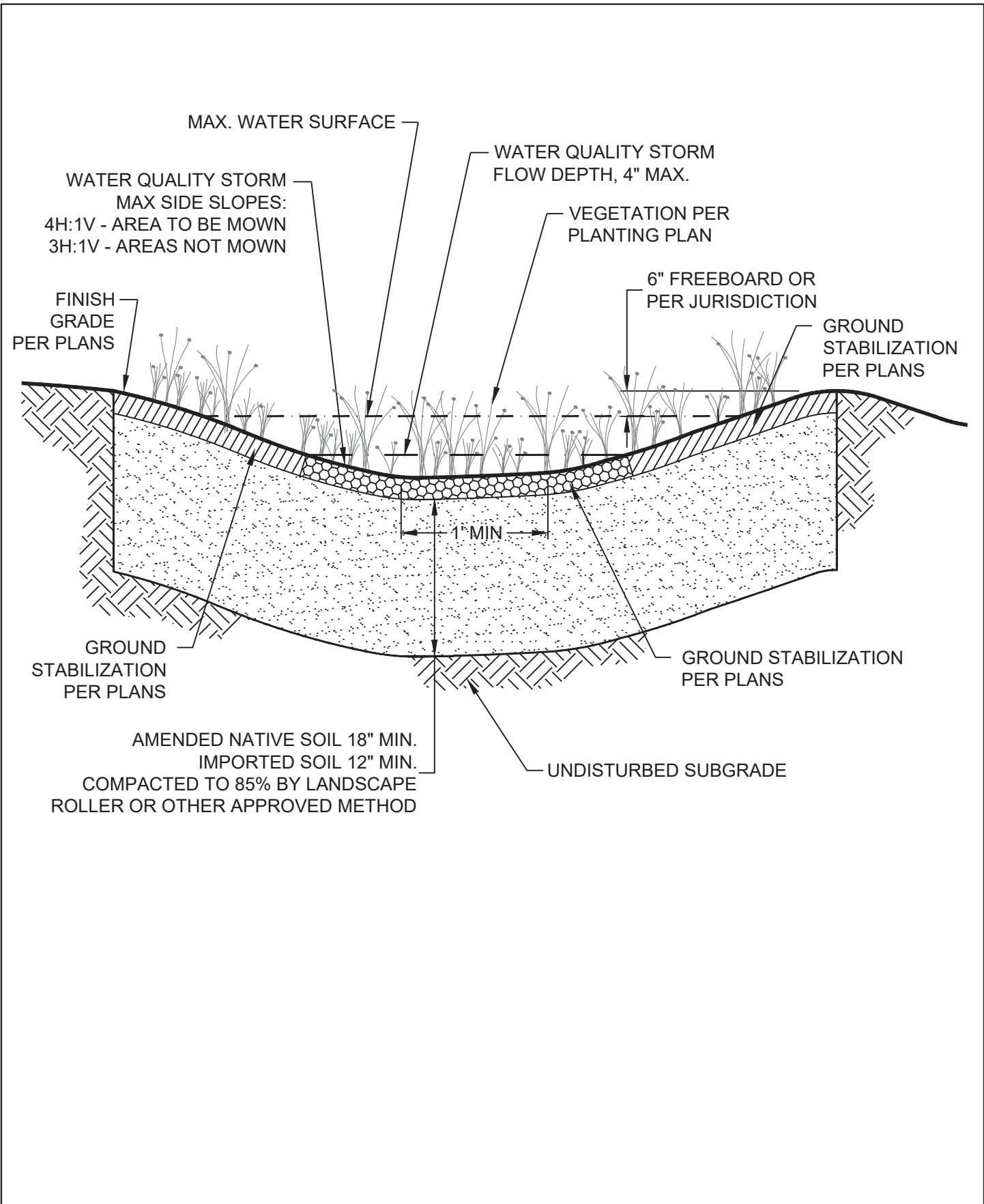

PLAN VIEW

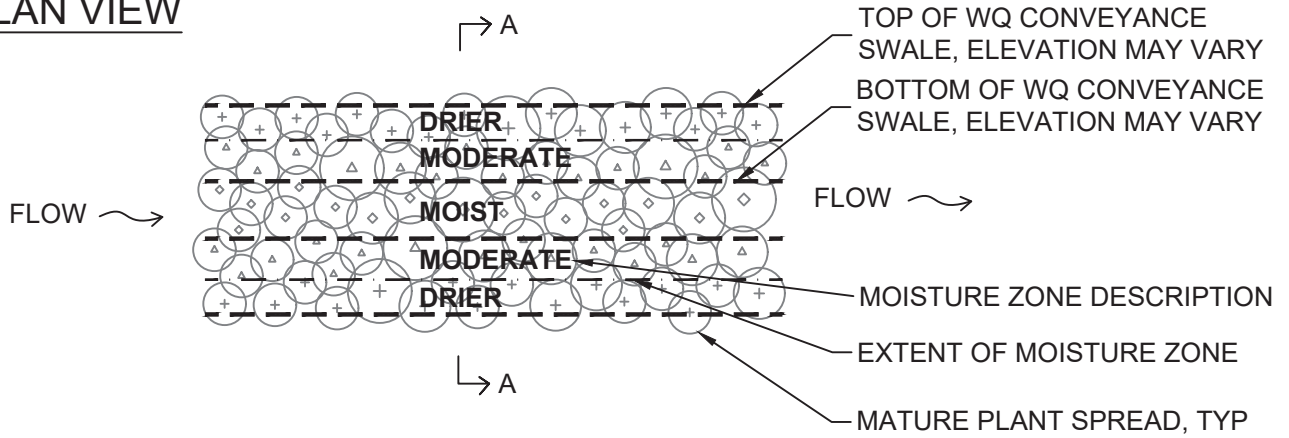

PROFILE VIEW

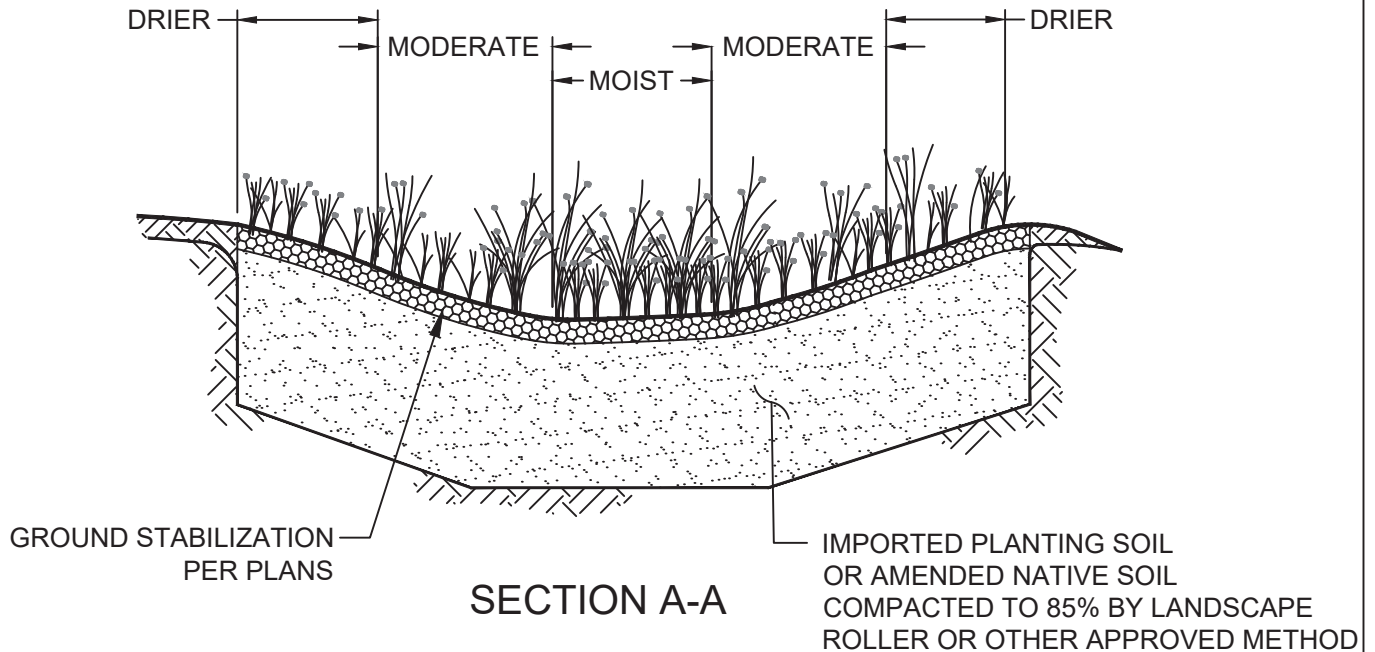

LEGEND:

— — INDICATES GRADE BREAK

- - - MOISTURE ZONE

PLANT SPECIES APPROPRIATE FOR MOISTURE ZONE:

- ⊕ DRIER
- △ MODERATE
- ◇ MOIST

NOTES:

1. THIS DETAIL IS PROVIDED AS A SCHEMATIC EXAMPLE OF THE RANDOM PLANT PLACEMENT AND 90% COVERAGE AFTER ESTABLISHMENT PERIOD DESIRED TO REDUCE EROSION AND WEEDS.
2. INSTALL PLANTS PER PLANS, ACCORDING TO LANDSCAPE DESIGN PLANT TABLE, WHICH SHOULD INCLUDE PLANT SPECIES, SPACING, AND QUANTITIES IN EACH MOISTURE ZONE.
3. MOISTURE ZONES VARY FROM THOSE SHOWN DEPENDING ON GRADING PLAN, LOCATION OF INLET(S) AND OUTLET(S) AND FACILITY SHAPE.

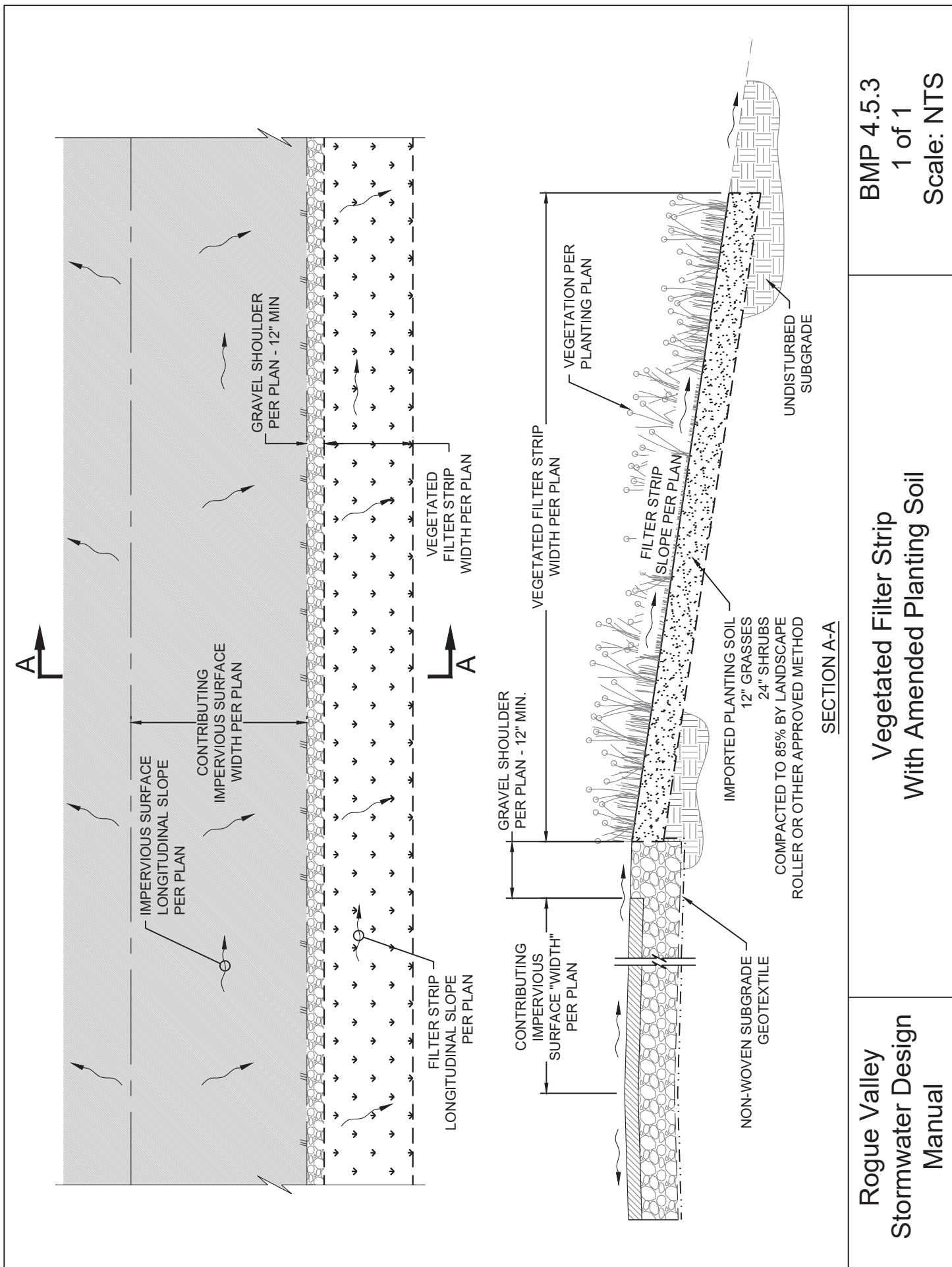

SECTION A-A

IMPORTED PLANTING SOIL
12" GRASSES
24" SHRUBS
COMPACTED TO 85% BY LANDSCAPE
ROLLER OR OTHER APPROVED METHOD

VEGETATION PER
PLANTING PLAN

UNDISTURBED
SUBGRADE

NON-WOVEN SUBGRADE
GEOTEXTILE

GRAVEL SHOULDER
PER PLAN - 12" MIN.

VEGETATED FILTER STRIP
WIDTH PER PLAN

FILTER STRIP
SLOPE PER PLAN

FILTER STRIP
LONGITUDINAL SLOPE
PER PLAN

VEGETATED
FILTER STRIP
WIDTH PER PLAN

IMPERVIOUS SURFACE
LONGITUDINAL SLOPE
PER PLAN

CONTRIBUTING
IMPERVIOUS SURFACE
WIDTH PER PLAN

GRAVEL SHOULDER
PER PLAN - 12" MIN

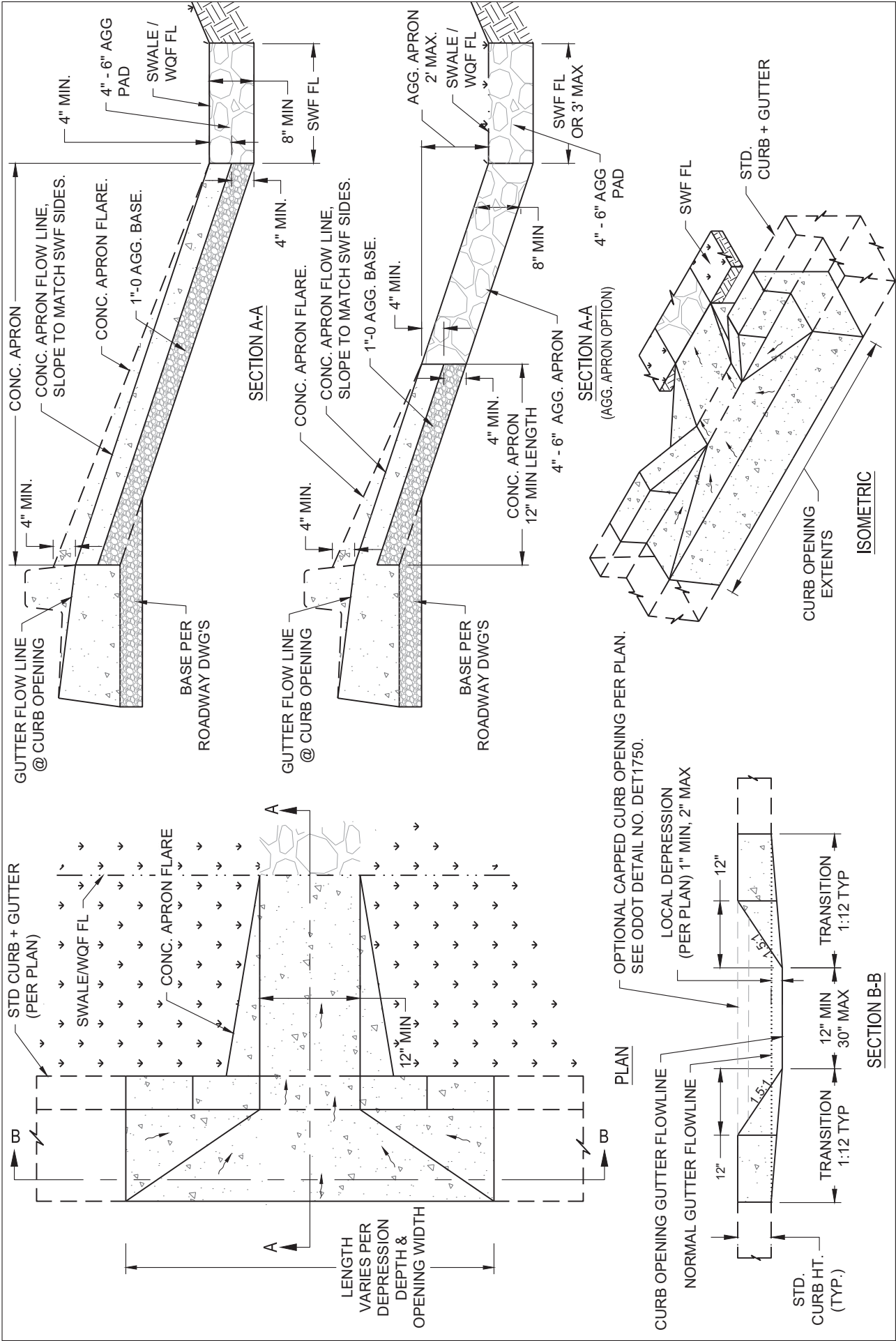

Rogue Valley Stormwater Design Manual

Roadway Curb Opening

Std. Detail 1.01
 1 of 1
 Scale: NTS

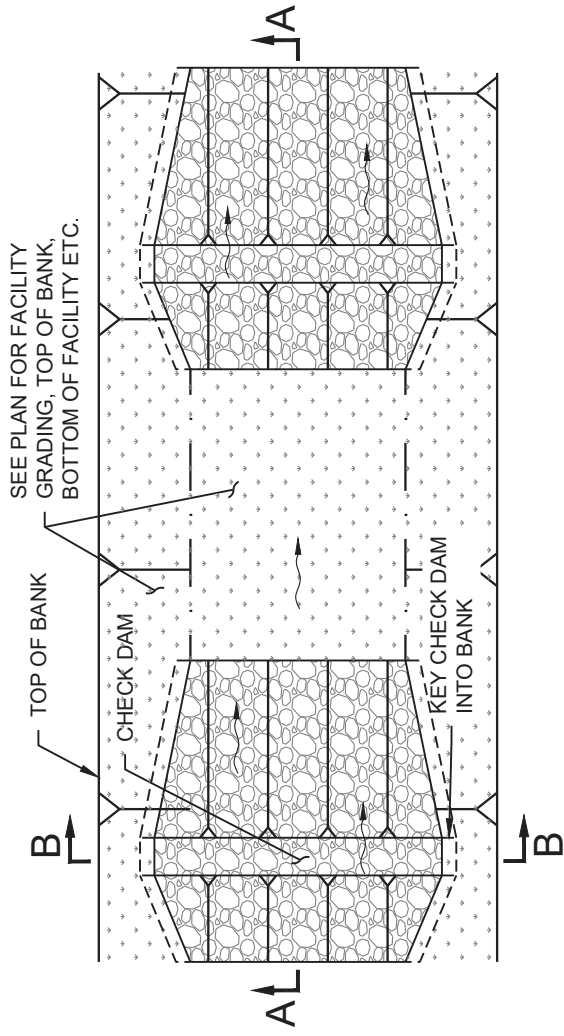

MAXIMUM CHECK DAM SPACING "L"	
SWALE GRADE	H = MIN. DAM HEIGHT
10%	15'
9%	16'
8%	18'
7%	21'
6%	25'
	33'

H = MIN. DAM HEIGHT

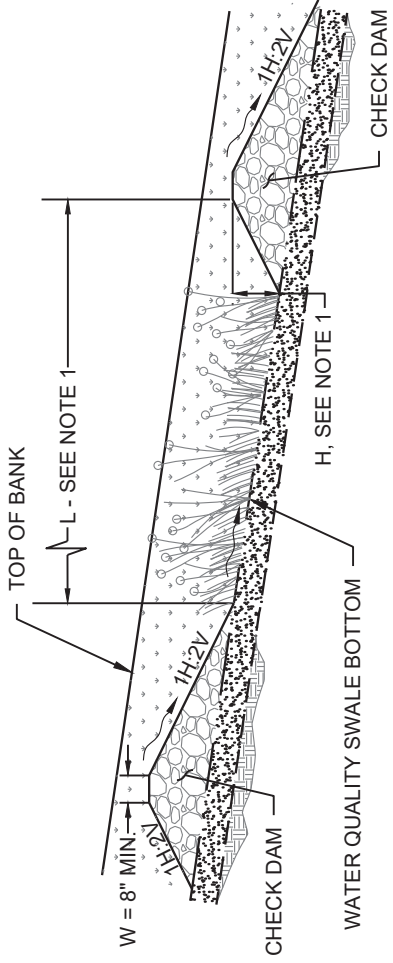

SECTION A-A

NOTES:
 1. ELEVATION AT TOP OF DOWNSTREAM CHECK DAM SHALL BE EQUAL TO TOE OF UPSTREAM CHECK DAM. REFER TO TABLE FOR MINIMUM CHECK DAM SPACING AND HEIGHT REQUIREMENTS.

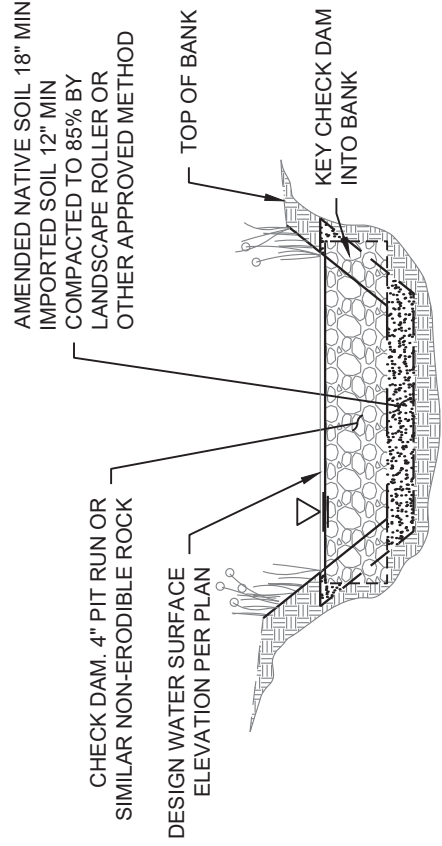

SECTION B-B

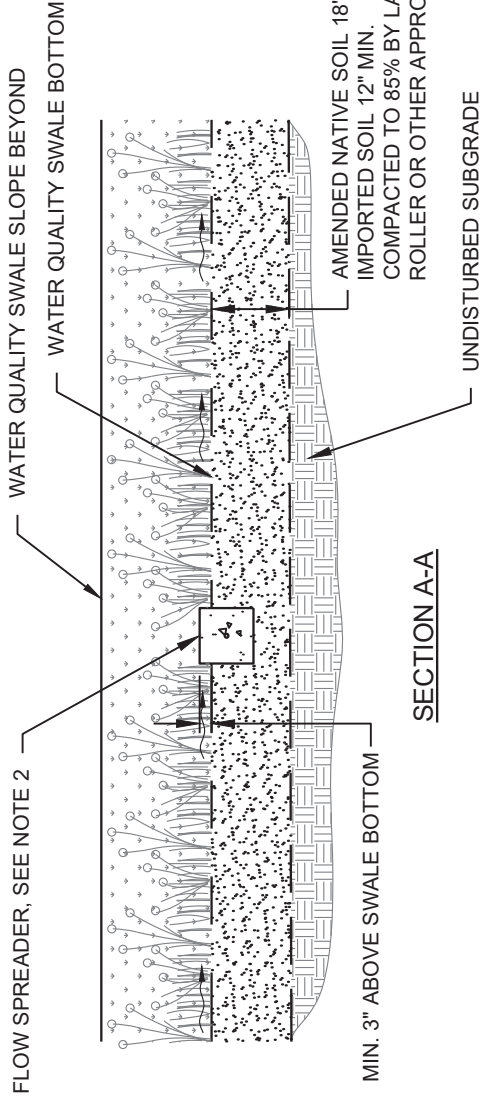
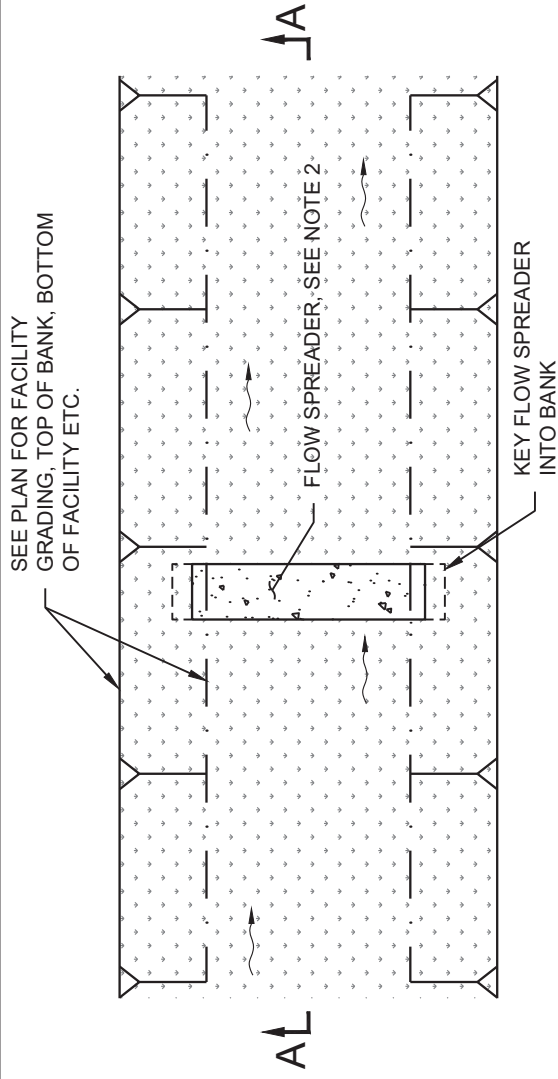

NOTES

1. FLOW SPREADERS SHALL BE INSTALLED WITHIN ALL WATER QUALITY SWALES WHICH HAVE A BOTTOM WIDTH OF FOUR FEET OR GREATER.
2. FLOW SPREADER SHOWN IS AN 8" x 8" CONCRETE SECTION. ALTERNATIVELY, 4" PIT RUN OR SIMILAR NON-ERODIBLE ROCK MAY BE USED.

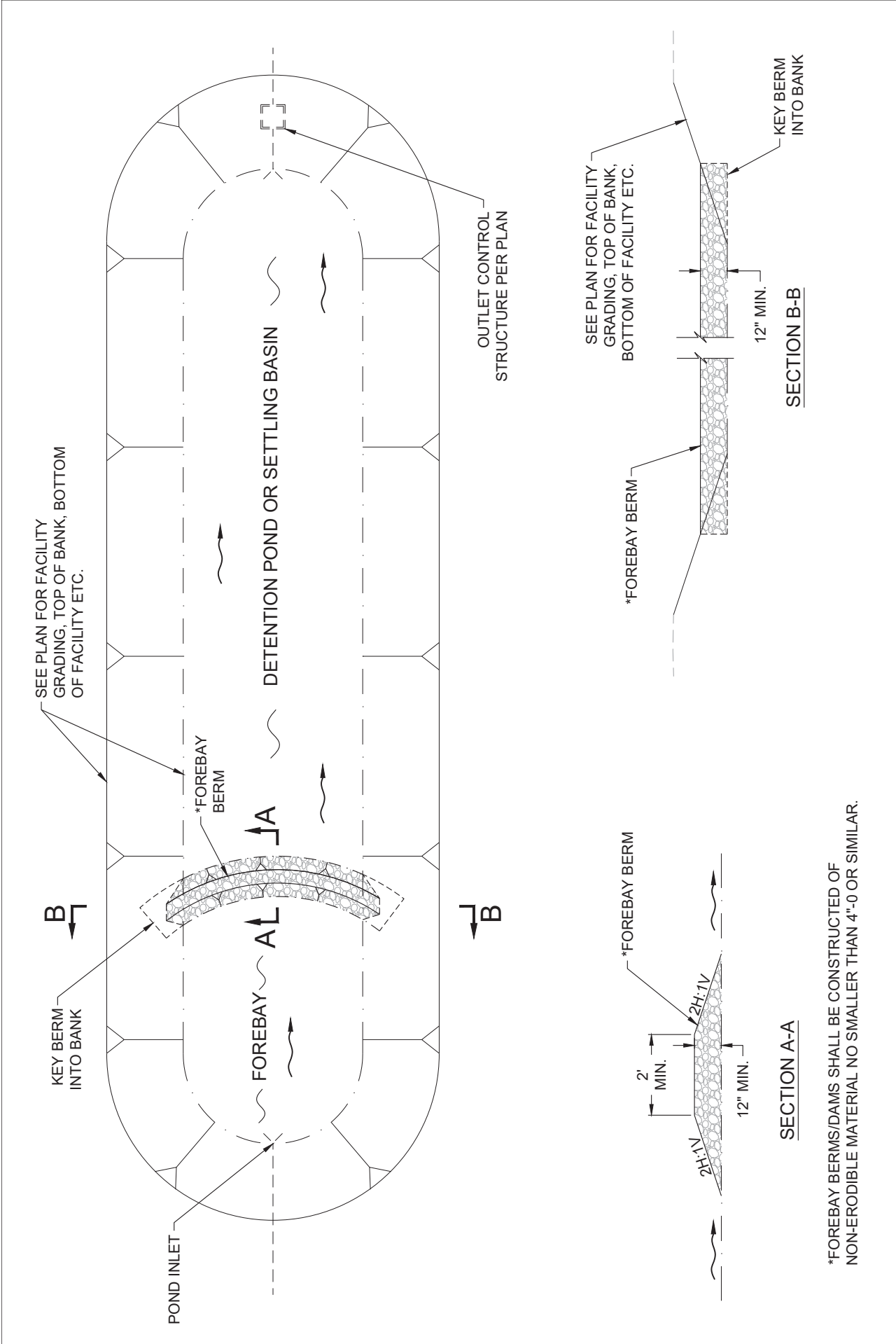

*FOREBAY BERMS/DAMS SHALL BE CONSTRUCTED OF NON-ERODIBLE MATERIAL NO SMALLER THAN 4"-0 OR SIMILAR.

<p>Rogue Valley Stormwater Design Manual</p>	<p>Forebay</p>	<p>Std. Detail 1.04 1 of 1 Scale: NTS</p>
--	----------------	---

TREE PROTECTION NOTES:

1. EXISTING TREES SHOWN TO REMAIN ARE TO BE PROTECTED DURING CONSTRUCTION. CHAINLINK FENCING (MIN. 4'-0" HEIGHT) SHALL BE INSTALLED AT THE DRIP LINE OF ALL TREES OR TREE GROUPS TO REMAIN. PARKING OF VEHICLES OR PERFORMING WORK WITHIN THESE AREAS OTHER THAN SHOWN ON THE PLAN, WILL NOT BE ALLOWED. THE TREE PROTECTION SHALL REMAIN DURING CONSTRUCTION. OTHER TREE PROTECTION MEASURES SHALL BE IN ACCORDANCE WITH THE CITY'S STANDARDS AND ORDINANCES.
2. DISPOSAL OF ANY WASTE MATERIAL SUCH AS, BUT NOT LIMITED TO, PAINT, ASPHALT, OIL SOLVENTS, CONCRETE, MORTAR, ETC. WITHIN THE CANOPY AREA OF THE EXISTING TREES SHALL NOT BE ALLOWED.
3. NO ATTACHMENTS OR WIRES OF ANY KIND OTHER THAN THOSE OF A PROTECTIVE NATURE, SHALL BE ATTACHED TO ANY TREE.
4. NO FILL OR EXCAVATION OF ANY NATURE SHALL OCCUR WITHIN THE DRIP LINE OF A TREE TO BE PRESERVED, UNLESS THERE IS A SPECIFIED WELL OR RETAINING WALL SHOWN ON THE GRADING PLAN.
5. NO MATERIALS SHALL BE STORED WITHIN THE DRIP LINE AREA OF A TREE TO BE PRESERVED.

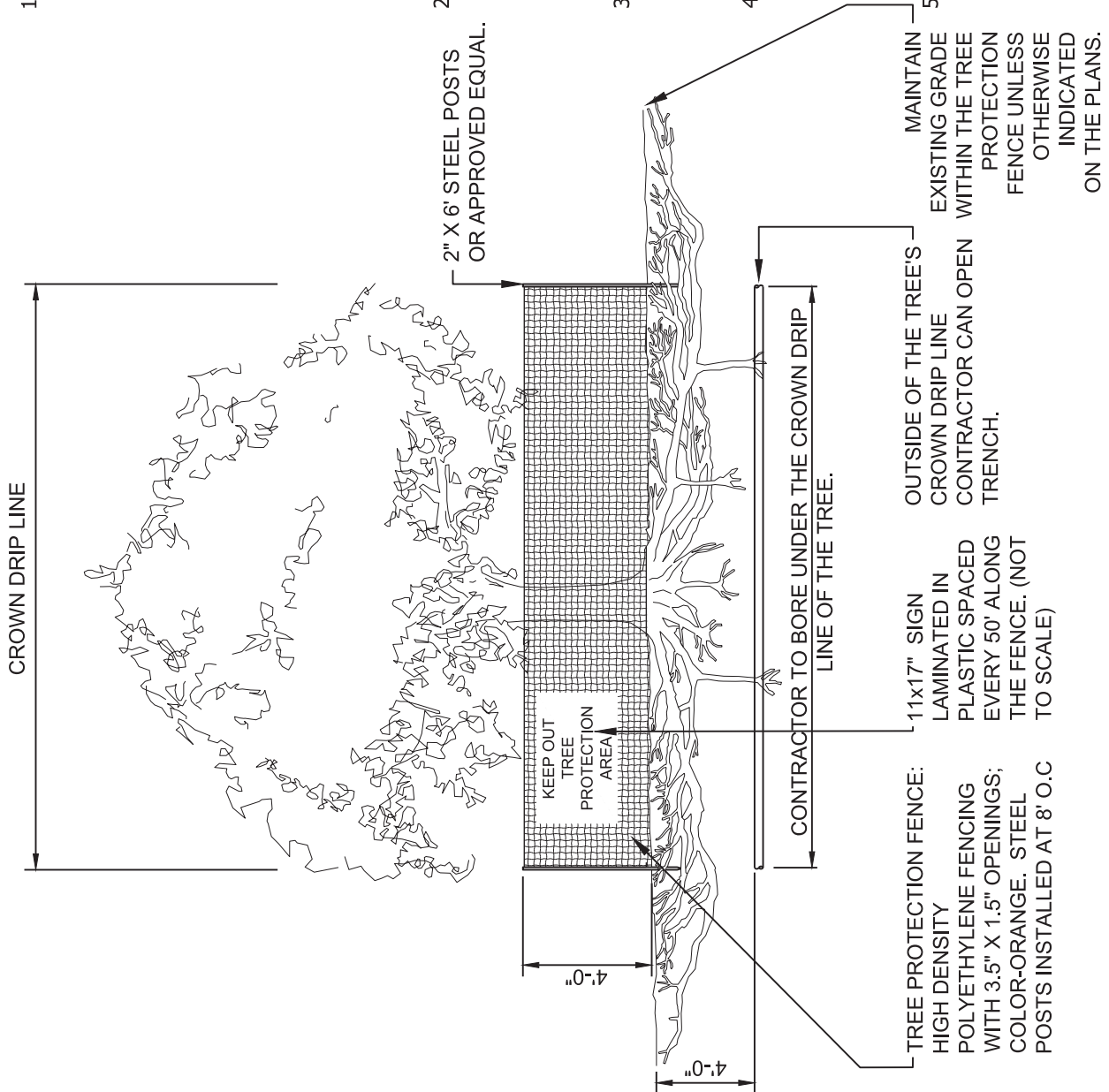

SECTION VIEW

TREE PROTECTION NOTES:

1. EXISTING TREES SHOWN TO REMAIN ARE TO BE PROTECTED DURING CONSTRUCTION. CHAINLINK FENCING (MIN. 4'-0" HEIGHT) SHALL BE INSTALLED AT THE DRIP LINE OF ALL TREES OR TREE GROUPS TO REMAIN. PARKING OF VEHICLES OR PERFORMING WORK WITHIN THESE AREAS OTHER THAN SHOWN ON THE PLAN, WILL NOT BE ALLOWED. THE TREE PROTECTION SHALL REMAIN DURING CONSTRUCTION. OTHER TREE PROTECTION MEASURES SHALL BE IN ACCORDANCE WITH THE CITY'S STANDARDS AND ORDINANCES.
2. DISPOSAL OF ANY WASTE MATERIAL SUCH AS, BUT NOT LIMITED TO, PAINT, ASPHALT, OIL SOLVENTS, CONCRETE, MORTAR, ETC. WITHIN THE CANOPY AREA OF THE EXISTING TREES SHALL NOT BE ALLOWED.
3. NO ATTACHMENTS OR WIRES OF ANY KIND OTHER THAN THOSE OF A PROTECTIVE NATURE, SHALL BE ATTACHED TO ANY TREE.
4. NO FILL OR EXCAVATION OF ANY NATURE SHALL OCCUR WITHIN THE DRIP LINE OF A TREE TO BE PRESERVED, UNLESS THERE IS A SPECIFIED WELL OR RETAINING WALL SHOWN ON THE GRADING PLAN.
5. NO MATERIALS SHALL BE STORED WITHIN THE DRIP LINE AREA OF A TREE TO BE PRESERVED.

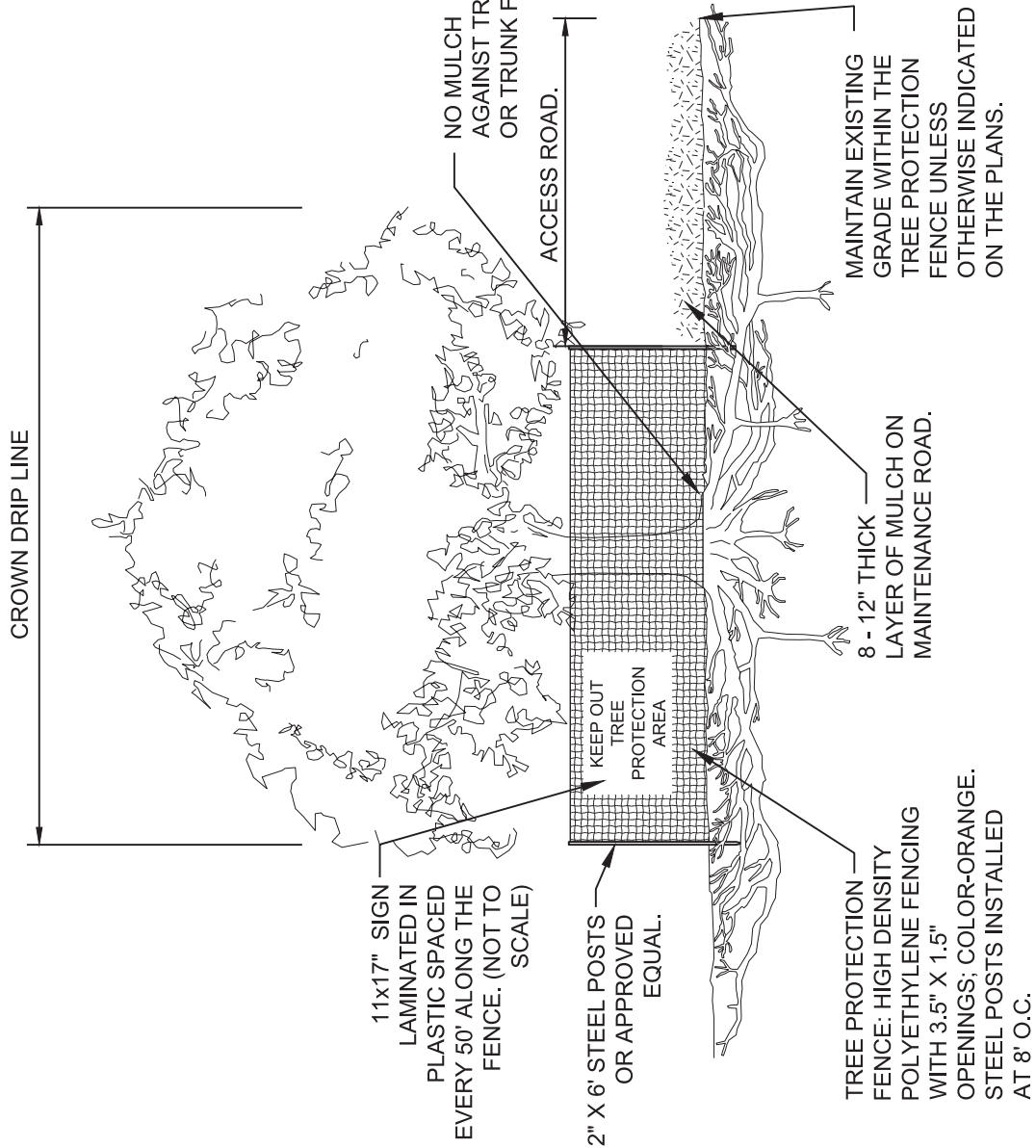

SECTION VIEW

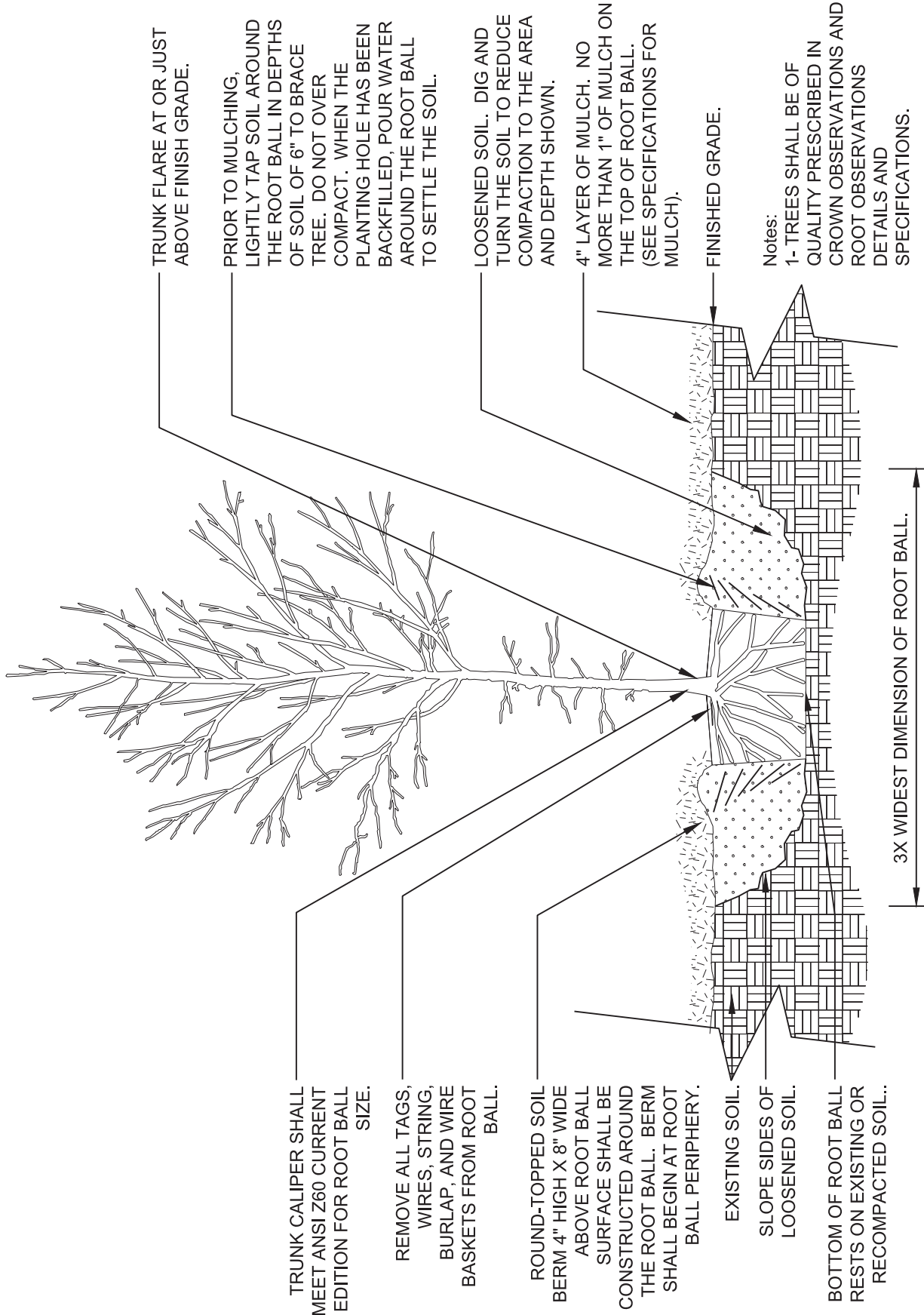

TRUNK FLARE AT OR JUST ABOVE FINISH GRADE.

PRIOR TO MULCHING, LIGHTLY TAP SOIL AROUND THE ROOT BALL IN DEPTHS OF SOIL OF 6" TO BRACE TREE. DO NOT OVER COMPACT. WHEN THE PLANTING HOLE HAS BEEN BACKFILLED, POUR WATER AROUND THE ROOT BALL TO SETTLE THE SOIL.

LOOSENED SOIL. DIG AND TURN THE SOIL TO REDUCE COMPACTION TO THE AREA AND DEPTH SHOWN.

4" LAYER OF MULCH. NO MORE THAN 1" OF MULCH ON THE TOP OF ROOT BALL. (SEE SPECIFICATIONS FOR MULCH).

FINISHED GRADE.

Notes:

1- TREES SHALL BE OF QUALITY PRESCRIBED IN CROWN OBSERVATIONS AND ROOT OBSERVATIONS DETAILS AND SPECIFICATIONS.

2- SEE SPECIFICATIONS FOR FURTHER REQUIREMENTS RELATED TO THIS DETAIL.

TRUNK CALIPER SHALL MEET ANSI Z60 CURRENT EDITION FOR ROOT BALL SIZE.

REMOVE ALL TAGS, WIRES, STRING, BURLAP, AND WIRE BASKETS FROM ROOT BALL.

ROUND-TOPPED SOIL BERM 4" HIGH X 8" WIDE ABOVE ROOT BALL SURFACE SHALL BE CONSTRUCTED AROUND THE ROOT BALL. BERM SHALL BEGIN AT ROOT BALL PERIPHERY.

EXISTING SOIL.

SLOPE SIDES OF LOOSENED SOIL.

BOTTOM OF ROOT BALL RESTS ON EXISTING OR RECOMPACTED SOIL.

3X WIDEST DIMENSION OF ROOT BALL.

